

FPT ePowertrain solutions

Innovation and sustainability have always been fundamental characteristics of FPT Industrial. In order to remain at the forefront of technological advancements and effectively respond to market needs, the Brand created ePowertrain department in 2018. With main hubs based in the R&D centers in Arbon, Switzerland, Coventry, UK and Turin, Italy, the ePowertrain department is focused on developing the powertrains of tomorrow, today. Being a global leader means setting new targets that grow more challenging every day. To reach them, we have drawn on our expertise along with the best innovative start-ups worldwide, through partnerships, acquisitions and joint ventures. Now, we can proudly display the results, showcasing our full range of ePropulsions and Energy Storage and Management solutions.

Electric Driveline

FPT Industrial is responding to the crucial challenges of transport sustainability, energy transition and CO₂ emission reduction with a complete range of innovative products. Designed to fully integrate all ePowertrain elements into a compact solution, capable of accommodating both the commercial load and the battery packs, the new eAxles and Central Drive offer outstanding performance and reliability, according to the mission application.

Specifications

Model:	eAX 840-R
Application:	HCV 4x2 & 6x2
Type:	Rear Axle
n. eMotors:	2
Peak Power (kW):	840
Peak Wheel Torque (Nm):	45.000
DC Voltage (V):	800 max
GAW (tonnes):	13
GCW (tonnes):	44
System efficiency:	>92%
Brake system:	DISC
Breaking Torque (Nm):	30.000
Weight (kg):	1.360
Dimensions (mm):	2.028 x 1.244 x 641
Power Density (kW/kg):	0,60
Gear - n. speed:	1
Gear ratio:	from 15 to 25
Durability Be10 (km):	up to 1.200.000

eDRIVELINE - ELECTRIC AXLES

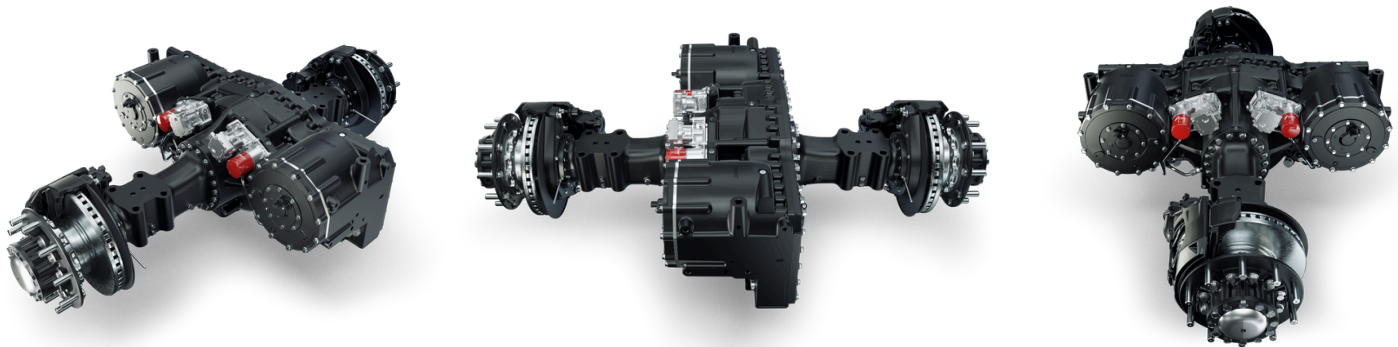

IMAGES SHOWN ARE FOR ILLUSTRATION PURPOSE ONLY

FOR INFORMATION ON THE AVAILABLE RATINGS NOT LISTED IN THIS DOCUMENT
PLEASE CONTACT THE FPT INDUSTRIAL SALES NETWORK OR VISIT OUR SITE WWW.FPTINDUSTRIAL.COM

SPECIFICATION SUBJECT TO CHANGE WITHOUT NOTICE

FPT ePowertrain solutions

Innovation and sustainability have always been fundamental characteristics of FPT Industrial. In order to remain at the forefront of technological advancements and effectively respond to market needs, the Brand created ePowertrain department in 2018. With main hubs based in the R&D centers in Arbon, Switzerland, Coventry, UK and Turin, Italy, the ePowertrain department is focused on developing the powertrains of tomorrow, today. Being a global leader means setting new targets that grow more challenging every day. To reach them, we have drawn on our expertise along with the best innovative start-ups worldwide, through partnerships, acquisitions and joint ventures. Now, we can proudly display the results, showcasing our full range of ePropulsions and Energy Storage and Management solutions.

Electric Driveline

FPT Industrial is responding to the crucial challenges of transport sustainability, energy transition and CO₂ emission reduction with a complete range of innovative products. Designed to fully integrate all ePowertrain elements into a compact solution, capable of accommodating both the commercial load and the battery packs, the new eAxles and Central Drive offer outstanding performance and reliability, according to the mission application.

Specifications

Model:	eAX 840-R
Application:	HCV 4x2 & 6x2
Type:	Rear Axle
n. eMotors:	2
Peak Power (kW):	840
Peak Wheel Torque (lb-ft):	33,200
DC Voltage (V):	800 max
GAW (lb):	26,000
GVW (lb):	97,000
System efficiency:	>92%
Brake system:	DISC
Breaking Torque (lb-ft):	22,000
Weight (lb):	3,000
Dimensions (inch):	80 x 50 x 25
Power Density (kW/lb):	0.28
Gear - n. speed:	1
Gear ratio:	from 15 to 25
Durability Be10 (mi):	up to 745,000

eDRIVELINE - ELECTRIC AXLES

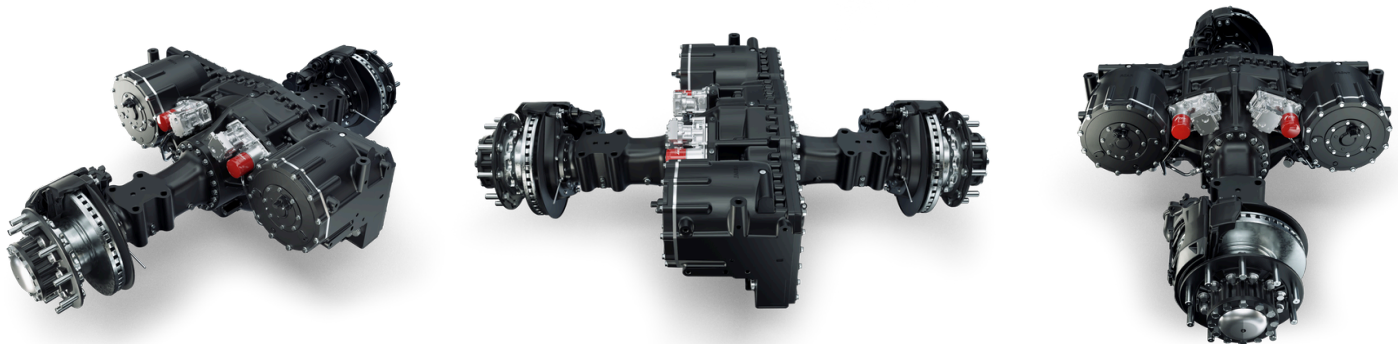

IMAGES SHOWN ARE FOR ILLUSTRATION PURPOSE ONLY

FOR INFORMATION ON THE AVAILABLE RATINGS NOT LISTED IN THIS DOCUMENT PLEASE CONTACT THE FPT INDUSTRIAL SALES NETWORK OR VISIT OUR SITE WWW.FPTINDUSTRIAL.COM

SPECIFICATION SUBJECT TO CHANGE WITHOUT NOTICE